



MANUAL 1976

6 HP

**MODEL 6604
6605**

INTRODUCTION	1
GENERAL SERVICE INFORMATION	2
FUEL SYSTEM	3
IGNITION SYSTEM	4
POWER HEAD	5
LOWER UNIT	6
MANUAL STARTER	7

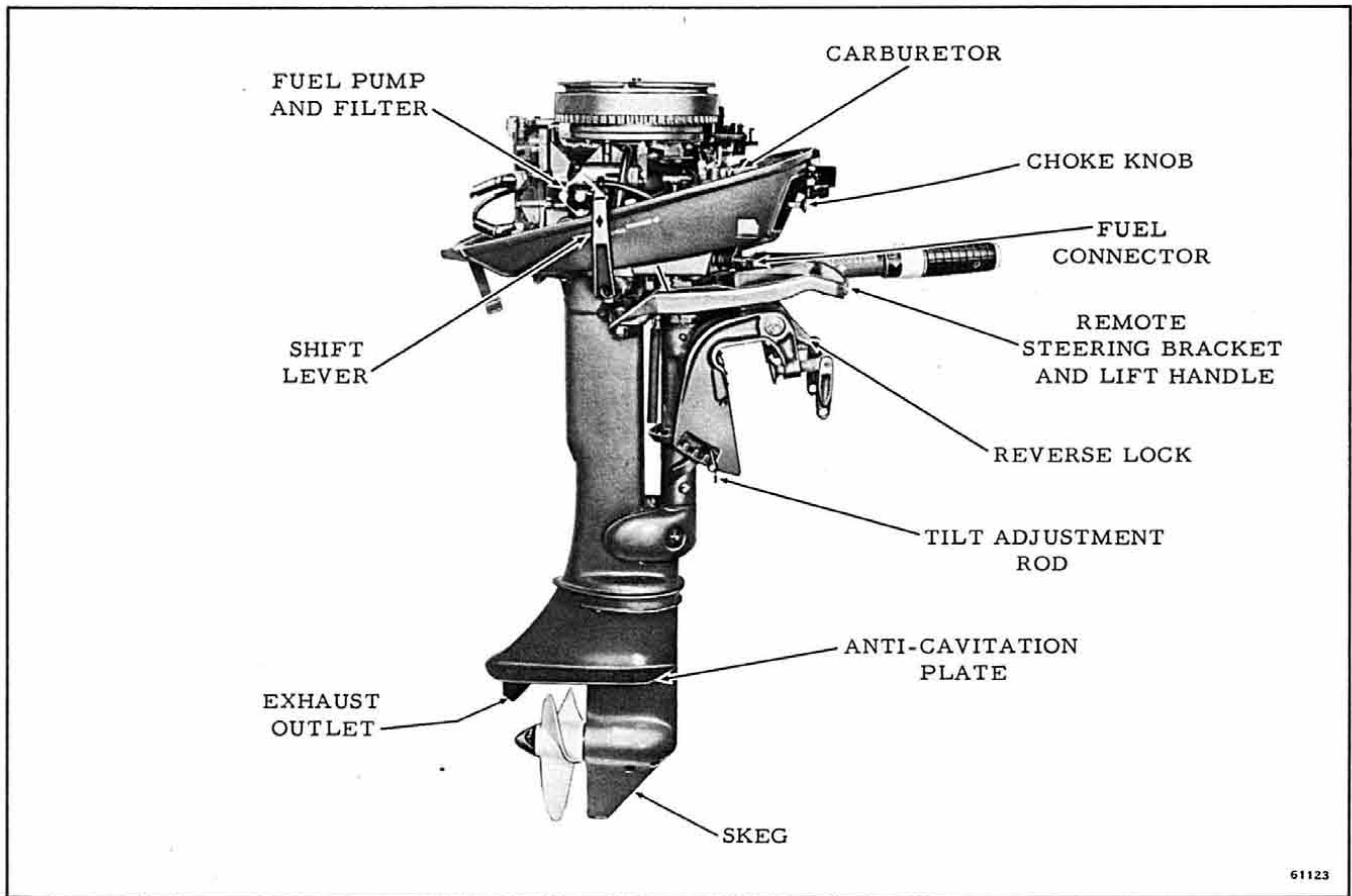

61123

Figure 1-1. Starboard Side

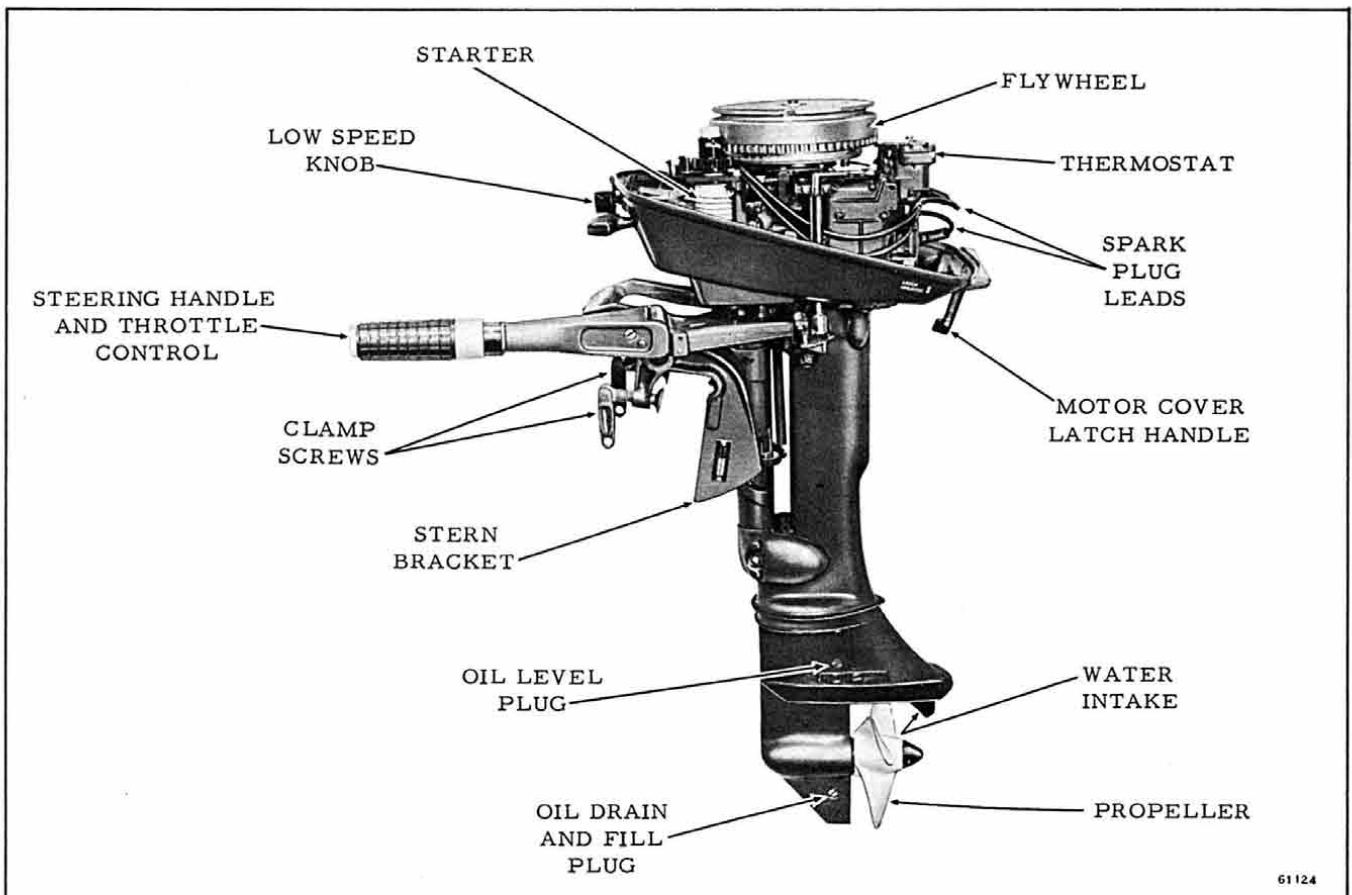

61124

Figure 1-2. Port Side

SPECIFICATIONS

Model Numbers	6602 - Standard length (15" transom) 6603 - 5" longer (20" transom)	Propeller drive pin	Part Number 307949, 3/16" x 1-25/64" stainless steel
*Horsepower (B.I.A. - certified)	6 hp at 4500 rpm	Propeller	8" diameter x 7" pitch, 3 blade
Full throttle operating range	4000 - 5000 rpm	Speed control	Twist-grip, synchronized throttle and spark
Tank test with test wheel	4500 rpm Part Number 379673	Gear shift control	Forward, neutral, and reverse
Engine type	2 cylinder, 2 cycle, alternate firing	Weight (without fuel tank)	Model 6602 - 51 pounds Model 6603 - 52 pounds (Fuel tank weight 11 pounds net)
Bore and stroke	1-15/16" bore x 1-1/2" stroke	Fuel capacity	6 gallons
Piston displacement	8.84 cubic inches	Starter	Manual, self-rewinding
Piston ring sets (2 per set)		Ignition	Flywheel magneto
standard	Part Number 378432	Spark plug	AC-M44C, Champion J6J, - 14mm
.030 oversize	Part Number 384336	Spark plug gap	.030 inch
Diameter of ring	1.9375 in. (standard)	Spark plug torque	17-1/2 - 20-1/2 Foot-pounds
Width of ring	.0935 - .0925 in.	Breaker point gap	.020 inch
Lbs. compression recommended when compressed	2 to 4 lbs.	Condenser Capacity	Part Number 580321 .18 - .22 Mfd.
Piston less rings standard	Part Number 376994	Coil	Part No. 580971
.030" oversize	Part Number 384335		
Crankshaft size top journal	.8080 - .8075 in.		
center journal	.8080 - .8075 in.		
bottom journal	.8080 - .8075 in.		
Connecting rod crank pin	.6690 - .6685 in.		
Carburetion	Single barrel, float feed, low-speed adjustment		
Float level setting	Flush with rim of casting		
Carburetor orifice plug	Hole size .052" Part Number 321108		
Inlet needle seat	.053" to .050". Use a #55 drill as gage		
Cooling system	Centri-Matic (combination positive displacement and centrifugal pump) Thermostatically controlled		
Propeller gear ratio	12:25		

COIL TEST SPECIFICATIONS

Stevens Tester Model ST-75				
Normal Polarity (Switch Setting Standard)			2.2	
Stevens Tester Model M.A.-75 or M-80				
Switch	Index Adjustment			
B	22			
Merc-O-Tronic				
Operating Amperage	Primary Resistance Min. - Max.	Secondary Continuity Min. - Max.		
1.6	.5 - .7	35 - 45		
Graham Tester Model 51				
Maximum Secondary	Maximum Primary	Coil Index	Minimum Coil Test	Max. Gap Index
5500	1.2	75	33	75

*Horsepower established at sea level. Allow 2% reduction per 1000' above sea level.