



**EVINRUDE**

**SERVICE**

**MANUAL  
1976**

200 HP

MODEL 200649  
200640

INTRODUCTION

**1**

GENERAL  
SERVICE  
INFORMATION

**2**

FUEL  
SYSTEM

**3**

IGNITION  
SYSTEM

**4**

POWER  
HEAD

**5**

LOWER  
UNIT

**6**

ELECTRICAL  
SYSTEM

**7**

REMOTE  
CONTROL

**8**

POWER TRIM  
AND TILT

**9**

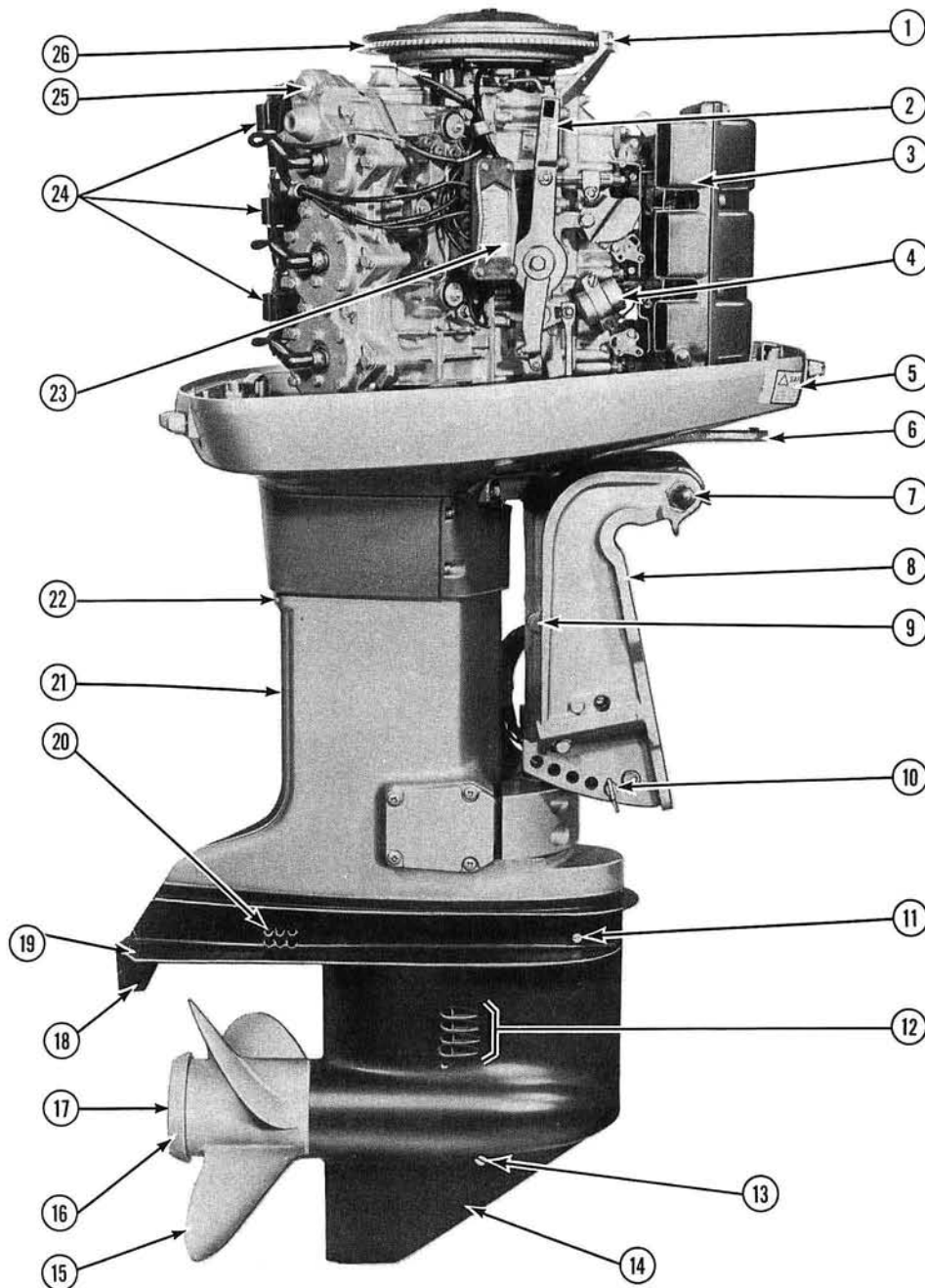

- |                             |                             |
|-----------------------------|-----------------------------|
| 1. Timing pointer           | 14. Skeg                    |
| 2. Throttle lever           | 15. Propeller               |
| 3. Air silencer             | 16. Converging ring         |
| 4. Choke solenoid           | 17. Exhaust outlet          |
| 5. Lower motor cover        | 18. Trim tab                |
| 6. Steering arm             | 19. Anti-cavitation plate   |
| 7. Tilt tube                | 20. Water outlet            |
| 8. Stern bracket            | 21. Exhaust housing         |
| 9. Trail lock               | 22. Exhaust relief          |
| 10. Thrust rod retainer     | 23. Power pack              |
| 11. Oil level plug          | 24. Ignition coils          |
| 12. Water intake            | 25. Thermostat housing      |
| 13. Oil drain and fill plug | 26. Flywheel and alternator |

61 649

Figure 1-1. Starboard View



## SPECIFICATIONS

Model Numbers . . . . . 200649 (20" transom)  
 200640 (25" transom)

\*Horsepower (B.I.A.-certified) . . . . . 200 hp at 5250 rpm

Full throttle operating range . . . . . 4750 to 5750 rpm

Tank test with test wheel part number 387388 . . . . . 4800 rpm

Engine type . . . . . 90° V-type, 6 cylinder, 2 cycle

Bore and stroke . . . . . 3.500" bore x 2.588" stroke

Piston displacement . . . . . 149.4 cubic inches

Piston ring sets (2 per set) standard

.020" oversize

.030" oversize

Diameter of ring . . . . . 3.500 in. (standard)

Width of ring (upper) . . . . . .0895 - .0900 in.

(lower) . . . . . .0615 - .0625 in.

Piston less rings

Standard

.020" oversize

.030" oversize

Crankshaft size

Top journal . . . . . 1.6204 - 1.6199

Center journals . . . . . 2.1875 - 2.1870

Bottom journal . . . . . 1.3784 - 1.3779

Connecting rod crank pin . . . . . 1.3762 - 1.3757

Carburetion . . . . . 3 carburetors - Float feed with fixed high and low-speed jets, Manual lever and remote control choke

Float level setting . . . . . Remove float bowl, turn carburetor upside down so weight of float closes needle; float should now be parallel to gasket surface.

Carburetor high speed orifice plug . . . . . Part Number 321731 Hole Size .058 in.

Carburetor low speed orifice plug . . . . . Part Number 318823 Hole Size .031

Inlet needle seat . . . . . .0745 - .0715  
 Use a #50 drill as gage

Cooling system . . . . . Thermostatically controlled recirculating system

Propeller gear ratio . . . . . 14:26

Gearcase lubricant capacity . . . . . 44.0 ozs. (1300 cc)

Propeller supplied with motor. †Aluminum 3 blade, 14-1/2" dia. x 19" pitch

\*\*Alternate propellers . . . . . †Aluminum 3 blade, 15-3/4" dia. x 13" pitch

Aluminum 3 blade, 15-1/2" dia. x 15" pitch

†Aluminum 3 blade, 15" dia. x 17" pitch

†Aluminum 3 blade, 14-1/4" dia. x 21" pitch

Aluminum 3 blade, 14-1/2" dia. x 23" pitch

Propeller nut size . . . . . 1-1/4"

Speed control . . . . . Remote control - synchronized throttle and spark

Gear shift control . . . . . POWER PILOT - forward, neutral, reverse - remote control

Weight (without fuel tank)

Model 200649 . . . . . 377 lbs.

Model 200640 . . . . . 381 lbs.

(Fuel tank weight 11 lbs. net)

Fuel tank supplied with motor capacity . . . . . 6 gallons

Starter . . . . . Electric and emergency rope

Starter amp draw

when cranking . . . . . 200 amps maximum

Starter RPM . . . . . 200 RPM for ignition

Generator system . . . . . Flywheel alternator

Fuse . . . . . Littlefuse 1 A.G. - 20 amp or Buss A.G. 20 amp (located on port side of motor in wire terminal area)

Ignition (Magneto breakerless C.D.) . . . . . Two Power Packs

Timing . . . . . 28° @4300-4600 RPM in gear

Spark plug . . . . . Champion UL-77V

Spark plug torque . . . . . 17-1/2" - 20-1/2" foot-pounds

Sensor air gap . . . . . Fixed

Ignition Coils . . . . . Part Number 581503

\*Horsepower established at sea level. Allow 2% reduction per 1000' above sea level.

\*\*Propeller supplied with motor may be exchanged for any one of the options of equal value if new and unused.

†Optional SST propellers available at extra cost.



NOTE

The recommended full power operating range for your outboard motor is from 4750 - 5750 R.P.M. In order to get the best performance from your outboard the upper end of this range, from 5250 - 5750 R.P.M., is the engine speed to use in selecting the proper propeller. The R.P.M. should be measured with your expected average load in the boat.

## IGNITION COIL TEST SPECIFICATIONS

| Stevens Model ST-75  |  |                               |
|--|--|-------------------------------|
| Reverse Polarity (Switch Setting CD)   | 1.9  |                               |
| Stevens Tester Model M.A.-75 or M.A.-80  |  |                               |
| <u>Switch</u><br>**A   | <u>Coil</u><br>581503                                    | <u>Index Adjustment</u><br>20 |
| **Use Model CD-1 Adapter<br>Red test clip to orange/black<br>Black test clip to orange |  |                               |
| Merc-O-Tronic with Capacitor Discharge Adapter Model 55-980                            |  |                               |
| Operating Amperage   | Primary Resistance                                       | Secondary Continuity          |
| Min. - Max.  | Min. - Max.  | Min. - Max.                   |
| 1.9  | .1 Ohm   | 8 - 20                        |
| Graham Tester Model 51   |  |                               |
| Maximum Secondary . . . . .  | 3,000 ohms   |                               |
| Maximum Primary . . . . .  | 0.6 ohm  |                               |
| Coil Index . . . . .   | 50   |                               |
| Coil Test Minimum AMPLIFIED . . . . .  | 27 (With secondary circuit "open.")                      |                               |
| Hi tension lead disconnected   |  |                               |
| Gap Index . . . . .  | 50 (Coil must fire spark gap on tester at this setting.) |                               |